

T-AGPZ-F158/F159/F208/F209/S8/S9 COMPACT AUTO. GUN OPERATION MANUAL

IMPORTANT: Read and follow all instructions and SAFETY PRECAUTIONS before using this equipment.

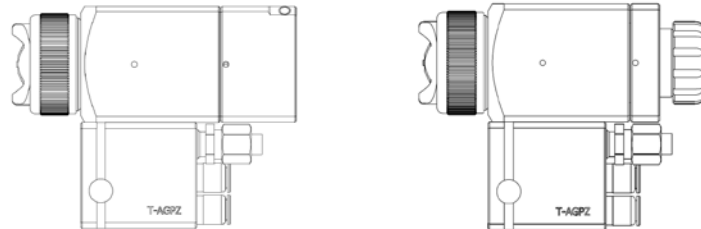

DESCRIPTION

T-AGPZ GUN is a low flow rate automatic spray gun specifically designed and suited for spraying small objects. This spray gun also has greatly improved maintenance performance thanks to the use of tungsten carbide in the fluid tip and needle which dramatically improves durability and anti-clogging properties, along with our industry-first “2 sep triggering system, which cuts cleaning time during color change to approximately half of what it was.

The compact, lightweight T-AGPZ gun is suitable for installing with robots or automatic spindle machines application, etc.

MODELS

Example:

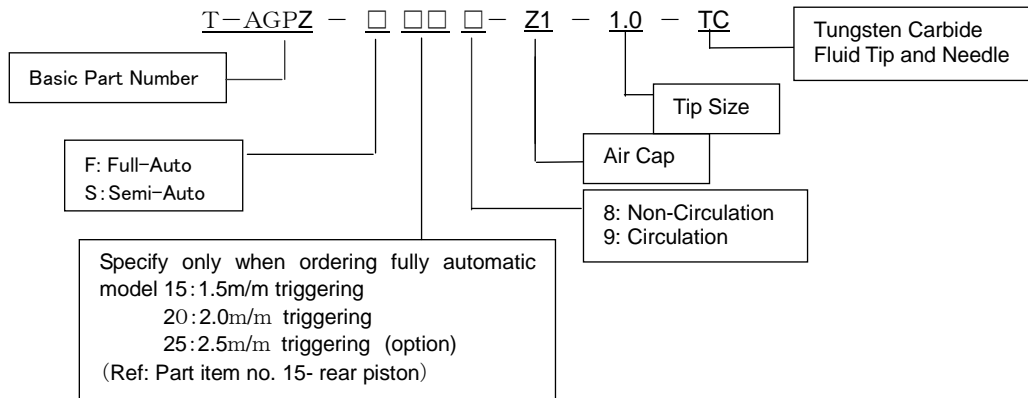

Chart 1

Air Cap		Fluid Tip Size (mm)	Pattern Size	Material of Fluid Tip and Needle
Marking	Part Number			
Z1	T-AGPZ-3-Z1	1.0	80mm	Tungsten Carbide

Chart 2

Air Cap	Tip Marking (mm)	Part Number (Tip, Needle & Piston Set)
Z1	1.0TC	T-AGPZ-440-1.0-TC



SAFETY PRECAUTIONS

This manual contains important information that ALL users should know and understand BEFORE using this equipment. This information relates to USER SAFETY and PREVENTING EQUIPMENT PROBLEMS. To help you recognize this information, we use the following terms to draw your attention to certain equipment labels and portions of this manual. Pay special attention to any label or information that is highlighted by one of these terms:

WARNING	Important information to alert you to a situation that might cause serious injury or loss of life if instructions are not followed.
CAUTION	Important information that tells how to prevent damage to equipment.
NOTE	Information that you should pay special attention to.

WARNING

The following hazards may occur during the normal use of this equipment. Please read the following chart.

HAZARD	CAUSE	SAFEGUARDS
<p>Fire</p> 	<p>Solvents and coatings can be highly flammable or combustible, especially when sprayed.</p>	<ol style="list-style-type: none"> 1. Adequate exhaust must be provided to keep the air free of accumulations of flammable vapors. 2. Smoking must never be allowed in spray area. 3. Fire extinguishing equipment must be present in the spray area. 4. Static discharges must be prevented. Ground (earth) all conductive objects in the spray area, such as a cleaning solvent bucket, fire extinguisher, etc. 5. When using solvents for cleaning; <ul style="list-style-type: none"> • Those used for equipment flushing must have a flash point equal to or greater than that of the coating. • Those used for general cleaning must have flash points above 100° F(37.8°C).
<p>Inhaling Toxic Substances</p> 	<p>Certain materials may be harmful if inhaled, or if there is contact with the skin.</p>	<ol style="list-style-type: none"> 1. Follow the requirements of the Material Safety Data Sheet supplied by coating material manufacturer. 2. Adequate exhaust must be provided to keep the air free of accumulations of toxic materials. 3. Use a mask or respirator whenever there is a chance of inhaling sprayed materials. The mask must be compatible with the material being sprayed and its concentration. Equipment must be as prescribed by an industrial hygienist or safety expert, and be NIOSH approved.
<p>Explosion Hazard-Incompatible Materials.</p> 	<p>Halogenated hydrocarbon Solvents- for example: methylene chloride and 1,1,1, -Trichloroethane are not chemically compatible with the aluminum that might be used in many system components. The chemical reaction caused by these solvents reacting with aluminum can become violent and lead to an equipment explosion.</p>	<p>The T-AGPZ spray gun can not be used with these solvents. Aluminum is widely used in other spray application equipment – such as material pumps, cups, regulators, valves, etc. Check all other equipment items before use of these solvents. Read the label or data sheet for the material you intend to spray. If in doubt as to where or not a coating or cleaning material is compatible, contact your material supplier.</p>
HAZARD	CAUSE	SAFEGUARDS
<p>General Safety</p>	<p>Improper operation or maintenance may create a hazard.</p>	<p>Operators should be given adequate training in the safe use and maintenance of the equipment (in accordance with the requirements of NFPA-33, Chapter 15 in U.S.). Users must comply with all local and national codes of practice and insurance company requirements governing ventilation, fire precautions, operation, maintenance and housekeeping (in the U.S., these are OSHA Sections 1910.94 and 1910.107 and NFPA-33).</p>

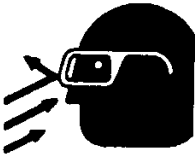
<p>Noise Levels</p> 	<p>The continuous A-weighted sound pressure level of this spray gun may exceed 85dB(A) depending on the air cap/nozzle set-up being used. Sound levels are measured using an impulse sound level meter and analyzer, when the gun is being used in a normal spraying application. Details of actual noise levels produced by the various air cap/nozzle set-ups are available on request.</p>	<p>Wear earplugs when using the spray gun.</p>
<p>Spraying solvent</p> 	<p>Pressured air/fluid passage may be broken when cleaning or flashing with solvent. The solvent may be harmful if contacted with eyes.</p>	<p>Always wear eye protection when spraying or cleaning the equipment.</p>
<p>MISUES:</p> <ul style="list-style-type: none"> • All spray guns project particles at high velocity and must never be aimed t any part of body. • Never exceed the recommended safe working pressure for any of the equipment used. • The fitting of non-recommended or non-original accessories or spare parts may create hazardous conditions. • Before dismantling the equipment for cleaning or maintenance, all pressures, air and material, must be isolated and released. <p>Disposal of non-metallic materials must be carried out in an approved manner. Burning may generate toxic fumes. The removal of waste solvents and coating materials should be carried out by an authorized local waste disposal service.</p>		

SPECIFICATION

	FULL-AUTO	SEMI-AUTO
Max. Air Pressure	0.7MPa (7 bar)	0.7MPa (7 bar)
Recommended Fluid Pressure	0.01MPa-0.1MPa (0.1-1 bar)	0.01MPa-0.1MPa (0.1-1 bar)
Recommended Atomization Air Pressure (CAP Air)	0.1MPa – 0.3MPa (1-3 bar)	0.1MPa – 0.3MPa (1-3 bar)
Cylinder Air Pressure	Front CYL 0.25MPa	0.25 – 0.4MPa
	Rear CYL 0.4MPa	
Fluid Inlet	6 x 4mm	6 x 4mm
FAN / CAP Air Inlet	6 x 4mm x 2	6 x 4mm x 2
Cylinder Air Inlet	6 x 4mm x 2 (Front & Rear)	6 x 4mm
Weight	550 g	507 g

INSTALLATION

Figure 1. Dimensions

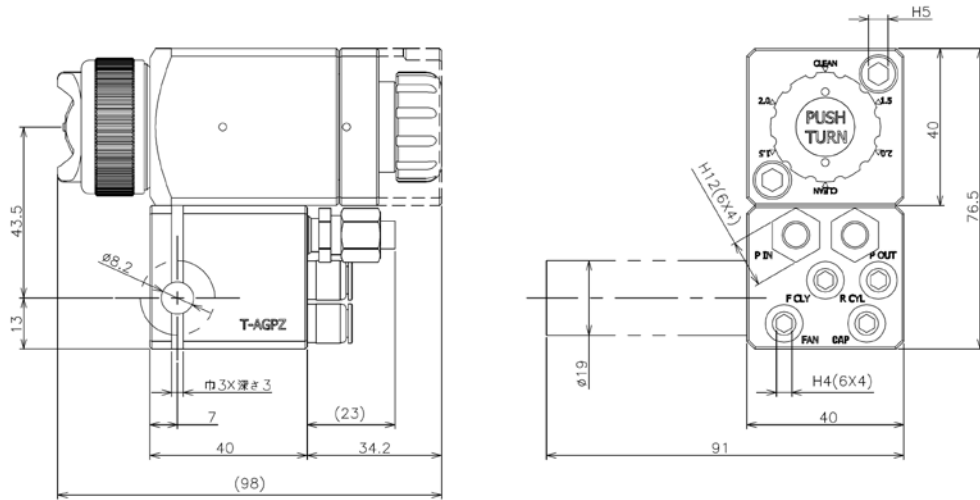

CAUTION

The air supplied to the gun should be clean air that removed any impurities.

OPERATION

Full-Auto Type (F)

1. Mix, prepare and strain the coating material to be sprayed according to paint manufacturer's instructions.
2. Adjust the Front CYL air at 0.25MPa and Rear CYL air at 0.4MPa.
3. Adjust CAP/FAN air at 0.1MPa - 0.15MPa.
4. Set the Fluid Delivery Level, for example, at 50 – 60cc/min by the fluid regulator HGB-510-R4 (option).
5. Turn on CYL air and test spray. Adjust fluid and air pressure until desired pattern is obtained. Control fluid delivery at source supply. Always attempt to keep CAP air as low as possible to minimize overspray.

Semi-Auto Type (S)

1. Mix, prepare and strain the coating material to be sprayed according to paint manufacturer's instructions.
2. Choose the triggering length between 1.5mm or 2.0mm and set it by turning the dial while pressing inward on it.
3. Adjust the CYL air at 0.25MPa - 0.4MPa.
4. Adjust CAP/FAN air at 0.1MPa - 0.15MPa.
5. Set the Fluid Delivery Level, for example, at 50 – 60cc/min by the fluid regulator HGB-510-R4 (option).
6. Turn on CYL air and test spray. Adjust fluid and air pressure until desired pattern is obtained. Control fluid delivery at source supply. Always attempt to keep CAP air as low as possible to minimize overspray.

WARNING

Risk of injury. Equipment and fluid may be under pressure. Pressure in the system must be relieved before beginning the cleaning procedure and before replacing any parts. Follow the procedures in the literature provided with the system.

CLEANING

1. When you clean the Full-Auto type gun, Rear CYL air should be stopped. In case of Semi-Auto type gun, you should set the dial to "CLEAN" position.
2. Relieve air pressure from pressure tank. Carefully follow instructions in bulletin sent with tank.
3. Replace material in container with a suitable solvent.
4. Re-pressurize system.
5. Trigger gun (Front CYL air / ON at FULL-AUTO) and repeat procedure until gun and hose are thoroughly Clean. A SolventSaver™ type hose and gun cleaner which supplies a mixture of air and solvent can be used to most effectively clean gun and hose internal passages. See "Accessories" for SolventSaver™. Wipe exterior of gun with a solvent dampened cloth.
6. If a recirculating system is used, it may be necessary to fit a shut off valve in return line to ensure fluid tip and forward portion of sprayhead passage are properly cleaned when flushed with solvent.

CAUTION

Do not totally submerge gun in solvent. It may damage the inside of the gun with solids.

CAUTION

The air cap can be immersed in solvent for cleaning. If orifices are clogged, use a cocktail stick or toothpick to remove obstruction. Never use a steel wire or hard instrument. This will damage air cap and result in a destroyed spray pattern.

REPLACEMENT

Tools required:

- Special tool for adjusting needle seal kit (for Item No. 5)
- 19mm Box Wrench (for Item No. 4)
- 2.5mm Hex Wrench (for Item No. 30)
- 4mm Hex Wrench (for Item No. 17, 19)
- 6mm Hex Wrench (for Item No. 31)

☆ **Replacing Tip, Needle & Piston Set (4)**

1. Relieve all air and fluid pressure in system.
2. It is recommended to remove the Gun from the Manifold (24) by removing Bolt (31) before carrying out any maintenance.
3. First, remove rear body (13 or 18) with 4mm Hex Wrench, then remove Needle Spring (12). Pull Needle Assy from Gun body. When pulling out the needle assy., use the bolt Hex (17 or 19) which could screw into the rear side of piston.
4. Remove Retaining Ring (1) and Air Cap (3).
5. Remove Fluid Tip with 19mm Box Wrench.
6. Reassemble in reverse order.
 - *Recommended torque for Fluid Tip:12N·m / for M5 Bolt (17, 19, 30): 2.5N·m
 - * Apply petroleum jelly on cylinder of gun body and MiniY-Packing (11) and insert into gun.
 - * Apply petroleum jelly (Vaseline) on the rear cylinder, piston and O-Ring (16).

CAUTION

***Please ensure that there is no foreign matter at the tip and the area where the tip will be set at the gun body.**

***It is recommended that Tip, Needle & Piston Set (4) and Needle Seal Kit (5) MiniY-Packing(11) should be replaced at the same time.**

***Tip, Needle & Piston Set (4) is a precision machining part set. Therefore, they should be handled with care and do not push and rotate the needle to the tip by hand after the tip has been set to the gun body. It may damage the tungsten part of tip and needle.**

☆ **Replacing Needle Seal Kit (5)**

1. Please follow the procedure of above replacing Tip, Needle & Piston Set (4) until #3.
2. Remove the Needle Seal Kit from the gun body by using special tool for adjusting needle packing T-AGPZ-34 (33 / optional accessory).
3. Set the Needle Seal Kit (5) to the special tool (option)
Insert and screw it to the gun body until it stops.
A slightly tighten it after it stops. Then the setting is completed.
The special tool is also used for checking the tightness of needle seal. If the needle movement is not smooth enough, then seal needs to be adjusted (loosen a little).

CAUTION

***It is recommended to use T-AGPZ-34 (33) the special tool for adjusting needle packing when you**

need to change the needle seal kit. The stem part of the tool is used for checking and adjusting the tightness of sealing. (If it is too tight, the needle can't move smoothly.)

*At the initial setting it has been set with the torque of 0.5N·m. After you reassemble all the parts and using the Cylinder Air at 0.2MPa, if the needle does not move smoothly, need to readjust the needle seal.

*Recommended Front Cylinder Air Pressure is 0.25MPa and Rear Cylinder Air Pressure is 0.4MPa.

*It is recommended to purchase T-AGPZ-34 (33) special tool, since the general tools in the market may not be easy to use for inserting the needle seal and adjusting the tightness.

Figure 5. Gun Exploded View

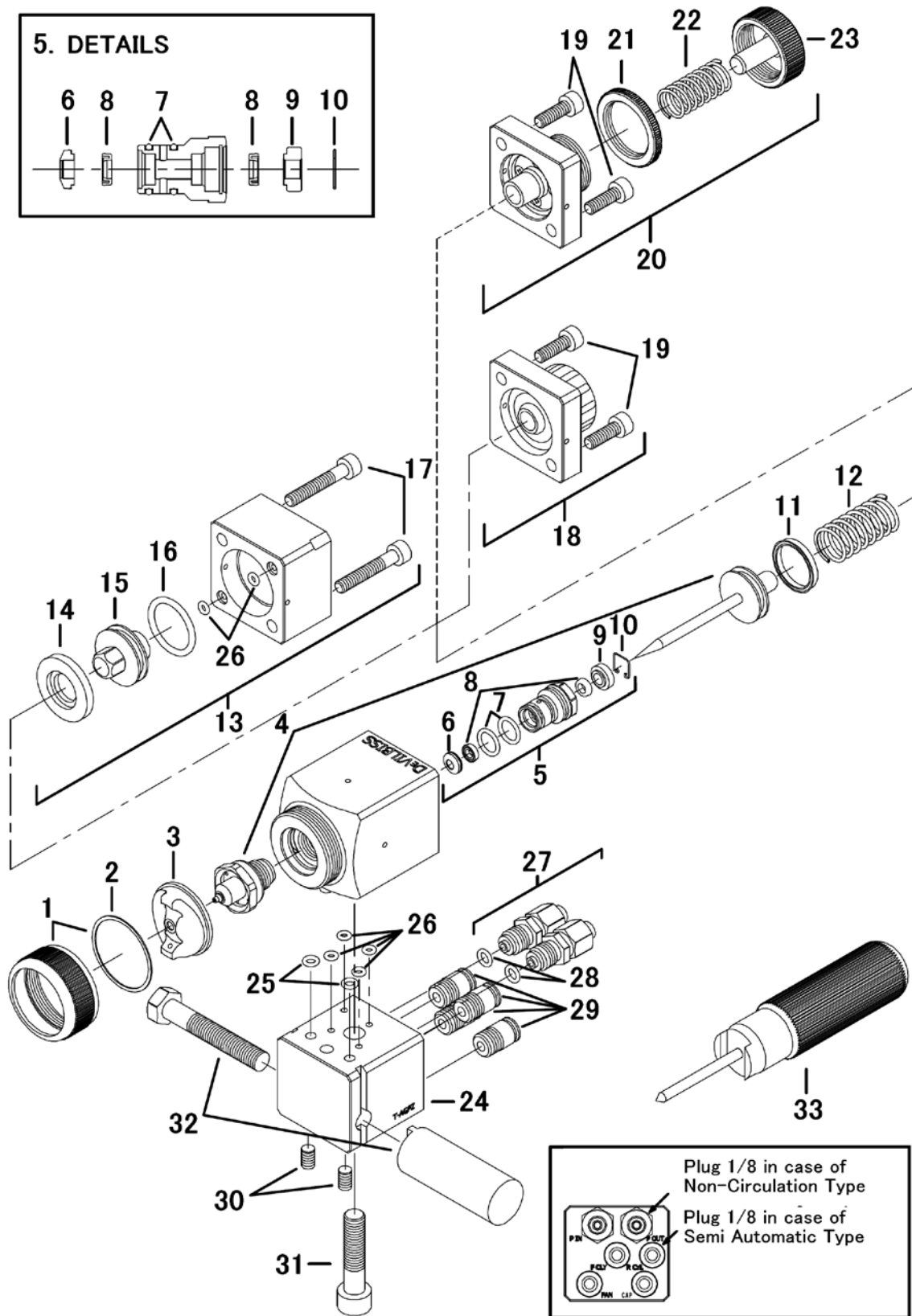



Item No.	Part Number	Description	Q'ty	Reference
1	T-AGPZ-6	Retaining Ring (with seat)	1	
2	JJ-50-K5	Seat Kit of 5	1	
3	Refer to Chart 1	Air Cap	1	
4	Refer to Chart 2	Tip, Needle & Piston Set	1	
5	T-AGPZ-10-1	Needle Seal Kit	1	Item no. 6,7,8,9,10
6	T-AGPZ-11-4-K5	Front Seal Kit of 5	1	
7	T-AGPZ-190-K5	O-Ring (S9) Kit of 5	2	Perfluoro
8	T-AGPZ-12	Omni-Seal (P4)	2	
9	T-AGPZ-11-3-K5	Seal Stopper Kit of 5	1	
10	T-AGPZ-15-K5	Seal Stopper Clip Kit of 5	1	
11	MY-18FX	Mini Y-Packing	1	
12	T-AGPZ-106	Needle Spring	1	
13	T-AGPZ-60-20	Rear Body (2.0mm Triggering)	1	
	T-AGPZ-60-15	Rear Body (1.5mm Triggering)	1	
14	T-AGPZ-115	Cover Ring	1	
15	T-AGPZ-116-20	Rear Piston (2.0mm Triggering)	1	
	T-AGPZ-116-15	Rear Piston (1.5mm Triggering)	1	
	T-AGPZ-116-25	Rear Piston (2.5mm Triggering)	1	Option
16	T-AGPZ-P20	O-Ring (P20)	1	Perfluoro
17	-----	Bolt with Hex hole M5xL30	2	
18	T-AGPZ-50	Rear Body (Semi-Auto)	1	
19	-----	Bolt with Hex hole M5xL15	2	
20	T-AGPZ-70	Manual Needle Position Adjustable Kit	1	Option
21	T-AGPZ-117	Lock Nut	1	
22	DA-34	Spring D	1	
23	T-AGPZ-118	Adjusting Knob	1	
24	-----	Manifold	1	Not for sale
25	T-AGPZ-140-K5	O-Ring (S4) Kit of 5	2	Perfuloro
26	T-AGPZ-130-K10	O-Ring (S3) Kit of 10	6	Perfuloro / 4 for Semi-Auto
27	EF7014-1-1	Fluid Connector Kit with O-Ring	2	1 for Non-Circulating
28	T-AGPV-131-K5	O-Ring (P5) Kit of 5	2	
29	EC-6-R1/8A-M-R1001	Air Connector	4	3 for Semi-Auto
30	-----	Set Screw M5xL8	2	
31	-----	SS Bolt with Hex Hole M8xL35	1	
32	KK-4995	Gun Stud	1	
33	T-AGPZ-34	Special Tool for Adjusting Needle Seal Kit	1	Option

SERVICE CHECK

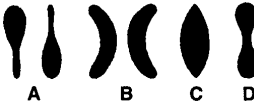

Normal Spray Pattern

The proper combination of fluid pressure, fan and atomization air pressure, and fluid tip size should result in a pattern of this shape.

PROBLEM	CAUSE	CORRECTION
Will not spray.	No pressure to gun. Piston stops moving.	Check air and material lines. Check CYL air pressure.
Improper spray pattern. 	A. Gun not adjusted properly. A, B Material build up on the air cap (3) or fluid tip. Damage on the air cap or fluid tip Note To determine where the material build up is, rotate the air cap 180° and test spray. If the pattern stays in the same position, the condition is caused by material build up on the fluid tip. If the pattern changes with air cap movement, the build up is in the air cap. C, D. Wrong material or material too thick. Insufficient material or atomizing air pressure too high.	A. Re-adjust. See "Operation Section". A, B Clean the air cap or fluid tip. Replace the air cap or fluid tip See "Preventive Maintenance". C, D Adjust material pressure or thin material. Increase material or reduce atomizing air pressure.
Jerky or fluttering spray. 	<ol style="list-style-type: none"> Insufficient material in the tank or an obstruction in the line. Gun material passage plugged. Worn Needle Seal Kit (5). Loose or damaged Fluid Tip. 	<ol style="list-style-type: none"> Fill tank or clear obstruction. Clean. Replace or tighten. Tighten or replace.
Air leaking from Rear Body.	<ol style="list-style-type: none"> Damaged or worn MiniY-Packing (11). Damaged cylinder of Gun Body. 	<ol style="list-style-type: none"> Replace. Replace.
Dripping from Fluid Tip.	<ol style="list-style-type: none"> Clogged by foreign matter Worn or damaged Fluid Tip or Needle Needle Spring damaged or deformed. 	<ol style="list-style-type: none"> Clean Replace. Replace.
Air or fluid leaking from 3 holes (2mm) of Gun Body (5).	Damaged or worn Needle Seal Kit (5)	Replace.

ACCESSORIES

Part Number	Description
SSL-10	Gun Lube
42884-214-K5	Cleaning Brush Kit of 5
GC-100-K48	Gun Cover Kit of 48
HD-505	Quick Cleaner (5L)
83GZ-5200	Solvent Saver (10L)

DEVILBISS DIVISION

RANSBURG INDUSTRIAL FINISHING KK

15-5, Fuku-ura 1Chome, Kanazawa-ku, Yokohama, Japan 〒236-0004
TEL.81-45-785-6371 FAX.81-45-785-6517

For more information, please contact: