

T-AFPV COMPACT AUTO. GUN OPERATION MANUAL

IMPORTANT: Read and follow all instructions and SAFETY PRECAUTIONS before using this equipment.

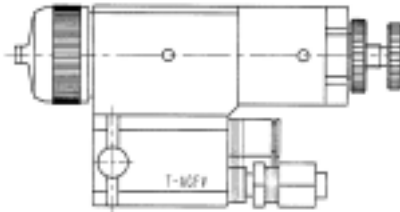

DESCRIPTION

T-AFPV GUN has been developed for coating small parts and less coating. This gun is smaller and lighter, which can achieve high transfer with high atomization with less air consumption. The small, lightweight T-AFPV gun is suitable for installing to robots or automatic machines. Models and application information follows;

MODELS

Example:

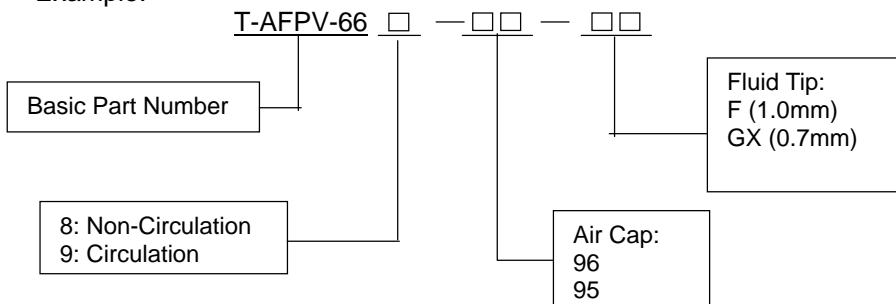

Chart 1

Marking	Air Cap		Fluid Tip Size (mm)	Pattern Size	Typical Applications
	Code No.				
	Part Number				
96	_____		F (1.0) GX (0.7)	100mm(F)	Most conventional materials Chlorinated solvents
	CV-39-96				
95	_____		F (1.0) GX (0.7)	140mm(F)	Most conventional materials Chlorinated solvents
	CV-39-95				

Chart 2

Air Cap	Tip Marking (mm)	Part Number (Tip & Needle Lapped Set)
96, 95	F (1.0)	T-AFPV-440-F
	GX (0.7)	T-AFPV-440-GX



SAFETY PRECAUTIONS

This manual contains important information that ALL users should know and understand BEFORE using this equipment. This information relates to USER SAFETY and PREVENTING EQUIPMENT PROBLEMS. To help you recognize this information, we use the following terms to draw your attention to certain equipment labels and portions of this manual. Pay special attention to any label or information that is highlighted by one of these terms:

WARNING	Important information to alert you to a situation that might cause serious injury or loss of life if instructions are not followed.
CAUTION	Important information that tells how to prevent damage to equipment.
NOTE	Information that you should pay special attention to.

WARNING

The following hazards may occur during the normal use of this equipment. Please read the following chart.

HAZARD	CAUSE	SAFEGUARDS
<p>Fire</p> 	<p>Solvents and coatings can be highly flammable or combustible, especially when sprayed.</p>	<ol style="list-style-type: none"> 1. Adequate exhaust must be provided to keep the air free of accumulations of flammable vapors. 2. Smoking must never be allowed in spray area. 3. Fire extinguishing equipment must be present in the spray area. 4. Static discharges must be prevented. Ground (earth) all conductive objects in the spray area, such as a cleaning solvent bucket, fire extinguisher, etc. 5. When using solvents for cleaning; <ul style="list-style-type: none"> · Those used for equipment flushing must have a flash point equal to or greater than that of the coating. · Those used for general cleaning must have flash points above 100 ° F(37.8).
<p>Inhaling Toxic Substances</p> 	<p>Certain materials may be harmful if inhaled, or if there is contact with the skin.</p>	<ol style="list-style-type: none"> 1. Follow the requirements of the Material Safety Data Sheet supplied by coating material manufacturer. 2. Adequate exhaust must be provided to keep the air free of accumulations of toxic materials. 3. Use a mask or respirator whenever there is a chance of inhaling sprayed materials. The mask must be compatible with the material being sprayed and its concentration. Equipment must be as prescribed by an industrial hygienist or safety expert, and be NIOSH approved.
<p>Explosion Hazard- Incompatible Materials.</p> 	<p>Halogenated hydrocarbon Solvents- for example: methylene chloride and 1,1,1, -Trichloroethane are not chemically compatible with the aluminum that might be used in many system components. The chemical reaction caused by these solvents reacting with aluminum can become violent and lead to an equipment explosion.</p>	<p>The T-AGB spray gun can be used with these solvents. However, aluminum is widely used in other spray application equipment – such as material pumps, cups, regulators, valves, etc. Check all other equipment items before use of these solvents. Read the label or data sheet for the material you intend to spray. If in doubt as to where or not a coating or cleaning material is compatible, contact your material supplier.</p>
HAZARD	CAUSE	SAFEGUARDS
<p>General Safety</p>	<p>Improper operation or maintenance may create a hazard.</p>	<p>Operators should be given adequate training in the safe use and maintenance of the equipment (in accordance with the requirements of NFPA-33, Chapter 15 in U.S.). Users must comply with all local and national codes of practice and insurance company requirements governing ventilation, fire precautions, operation, maintenance and housekeeping (in the U.S., these are OSHA Sections 1910.94 and 1910.107 and NFPA-33).</p>

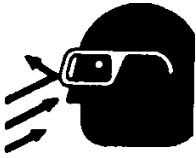
<p>Noise Levels</p> 	<p>The continuous A-weighted sound pressure level of this spray gun may exceed 85dB(A) depending on the air cap/nozzle set-up being used. Sound levels are measured using an impulse sound level meter and analyzer, when the gun is being used in a normal spraying application. Details of actual noise levels produced by the various air cap/nozzle set-ups are available on request.</p>	<p>Wear earplugs when using the spray gun.</p>
<p>Spraying solvent</p> 	<p>Pressured air/fluid passage may be broken when cleaning or flashing with solvent. The solvent may be harmful if contacted with eyes.</p>	<p>Always wear eye protection when spraying or cleaning the equipment.</p>
<p>MISUES:</p> <ul style="list-style-type: none"> · All spray guns project particles at high velocity and must never be aimed t any part of body. · Never exceed the recommended safe working pressure for any of the equipment used. · The fitting of non-recommended or non-original accessories or spare parts may create hazardous conditions. · Before dismantling the equipment for cleaning or maintenance, all pressures, air and material, must be isolated and released. <p>Disposal of non-metallic materials must be carried out in an approved manner. Burning may generate toxic fumes. The removal of waste solvents and coating materials should be carried out by an authorized local waste disposal service.</p>		

SPECIFICATION

Max. Air Pressure:	0.9Mpa (9 bar)
Max. Fluid Pressure:	1.4Mpa (14 bar)
Cylinder Air Pressure:	Min. 0.34Mpa (3.4 bar) Max. 0.49Mpa (4.9 bar)
Air Consumption;	70L/min. (Gun Inlet pressure 0.15Mpa)
Weight:	265g (Gun Body)
Mounting Stud:	Dia. 19mm x 51mm
Fluid Tube:	6 x 4mm
CYL Air Tube:	6 x 4mm
CAP Air Tube:	6 x 4mm
FAN Air Tube:	6 x 4mm

INSTALLATION

Figure 1. Dimensions

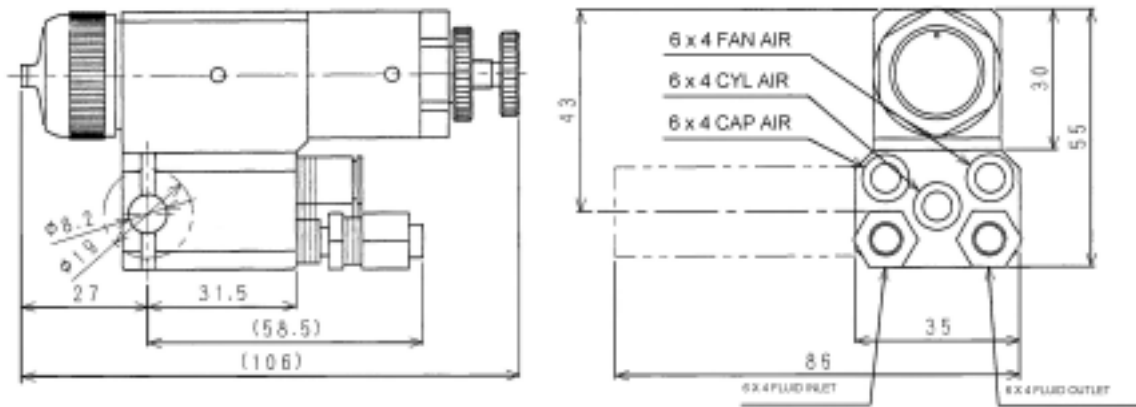
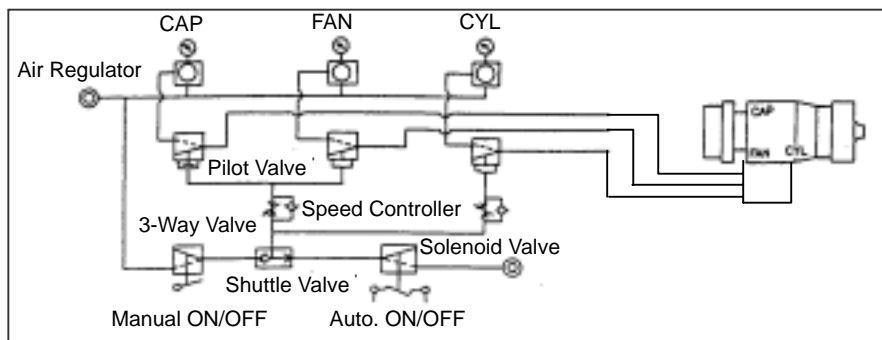

Figure 2. Installation



Mount the gun with the stud (18) or tighten with Manifold (19) 8.2mm whole.

CAUTION

**The air supplied to the gun should be clean air that removed any impurities.
To circulate the paint for Non-circulate body, open the passage for paint circulation at Gun Body (5) and remove the plug of Manifold (19), then install the fluid nipple.**

OPERATION

1. Mix, prepare and strain the coating material to be sprayed according to paint manufacturer's instructions.
2. Adjust the CYL air at 0.34~0.49Mpa. (3.4~4.9 bar)
3. Turn Adjusting Screw (17) counter-clockwise 3.5 turns from fully closed position and fix with Lock Nut (16). This makes the Needle fully opened.
4. Adjust CAP/FAN air at 0.15Mpa(1.5 bar).
5. Adjust fluid pressure 0.07~0.1Mpa.
6. Turn on CYL air and test spray. Adjust fluid and air pressure until desired pattern is obtained. Control fluid delivery at source supply. Always attempt to keep CAP air as low as possible to minimize overspray.

WARNING

Risk of injury. Equipment and fluid may be under pressure. Pressure in the system must be relieved before beginning the cleaning procedure and before replacing any parts. Follow the procedures in the literature provided with the system.

CLEANING

1. Relieve air pressure from pressure tank. Carefully follow instructions in bulletin sent with tank.
2. Replace material in container with a suitable solvent.
3. Re-pressurize system.
4. Trigger gun and repeat procedure until gun and hose are thoroughly clean
A SolventSaver™ type hose and gun cleaner which supplies a mixture of air and solvent can be used to most effectively clean gun and hose internal passages. See "Accessories" for SolventSaver™. Wipe exterior of gun with a solvent dampened cloth.
5. If a recirculating system is used, it may be necessary to fit a shut off valve in return line to ensure fluid tip and forward portion of sprayhead passage are properly cleaned when flushed with solvent.

CAUTION

Do not totally submerge gun insolvent. It may damage the inside of the gun with solids.

CAUTION

The air cap can be immersed in solvent for cleaning. If orifices are clogged, use a cocktail stick or toothpick to remove obstruction. Never use a steel wire or hard instrument. This will damage air cap and result in a destroyed spray pattern.

REPLACEMENT

Tools required:

- Crescent wrench
- 16mm Box Wrench (for Item No. 3)
- Pliers (for Needle Assy)
- 3, 6, 12, 13, 24mm Open Wrench (for Item No. 8, 13, 22, 11, 15)
- 2.5, 4mm Hex Wrench (for Item No. 23, 24, 25)
- 13mm Box Wrench (for Item No. 7)

Fluid Tip (3)

1. Relieve all air and fluid pressure in system.
2. It is recommended to remove the Gun from the Manifold (19) by removing Bolt (24) before carrying out any maintenance.
3. First, remove End Cap (15) with 24mm Open Wrench, then remove Needle Spring (14). Pull Needle Assy from Gun body with Pliers.
4. Remove Retaining Ring (1) and Air Cap (2).
5. Remove Fluid Tip(3) with 16mm Box Wrench.
6. Reassemble in reverse order. Recommended torque of Fluid Tip: 13~14Nm.

CAUTION

It is recommended that Fluid Tip(3), Needle(8), Needle Seal Kit(6) and MiniY-Packing(10) be replaced at the same time.

Replacing Needle(8), MiniY-Packing(10)

1. First, remove End Cap(15) with 24mm Open Wrench, then remove Needle Spring (14). Pull Needle Assy from Gun Body with Pliers.
2. Using 13mm Open Wrench for Piston (11), 6mm Open Wrench for Lock Nut (13), remove Lock Nut (13).
3. Using 13mm Open Wrench for Piston (11), 3mm Open Wrench for Needle (8), remove Needle (8) from Piston (11).

CAUTION

Do not try to remove Needle(8) with Lock Nut (13) installed as it may cause the damage.

Reassembling Needle Assy

1. Apply small amount of liquid gasket on thread of Needle (8) and screw into Piston (11).
2. Using 13mm Open Wrench for Piston (11), tighten Needle (8) with 3mm Open Wrench.
3. Screw Lock Nut (13) into Needle (8).
4. Using 13mm Open Wrench for Piston, tighten Lock Nut (13) with 6mm Open Wrench.
Recommended torque: 0.8~1.0Nm

Replacing Needle Seal Kit (6)

1. Remove End Cap (15) with 24mm Open Wrench and pull Needle Assy from Gun Body with Pliers.
2. Remove Housing (7) with 13mm Box Wrench first and then remove Needle Seal Kit (6).
3. Set Housing (7) and Needle Seal Kit (6) on 13mm Box Wrench and assemble on Gun Body (5).
4. Apply petroleum jelly on cylinder of gun body and MiniY-Packing (10) and insert into gun.
5. Apply petroleum jelly on Needle Spring (14) and assemble Adjusting Screw (17) at the position of 3.5 counter-clockwise turns from fully closed position and fix it with Lock Nut (16).
6. Pressure 0.35Mpa on CYL and check the movement of needle. If air leaks from 3mm hole on gun body, bind seal tape 1.5 laps on thread of Housing (7).

Figure 5. Gun Exploded View

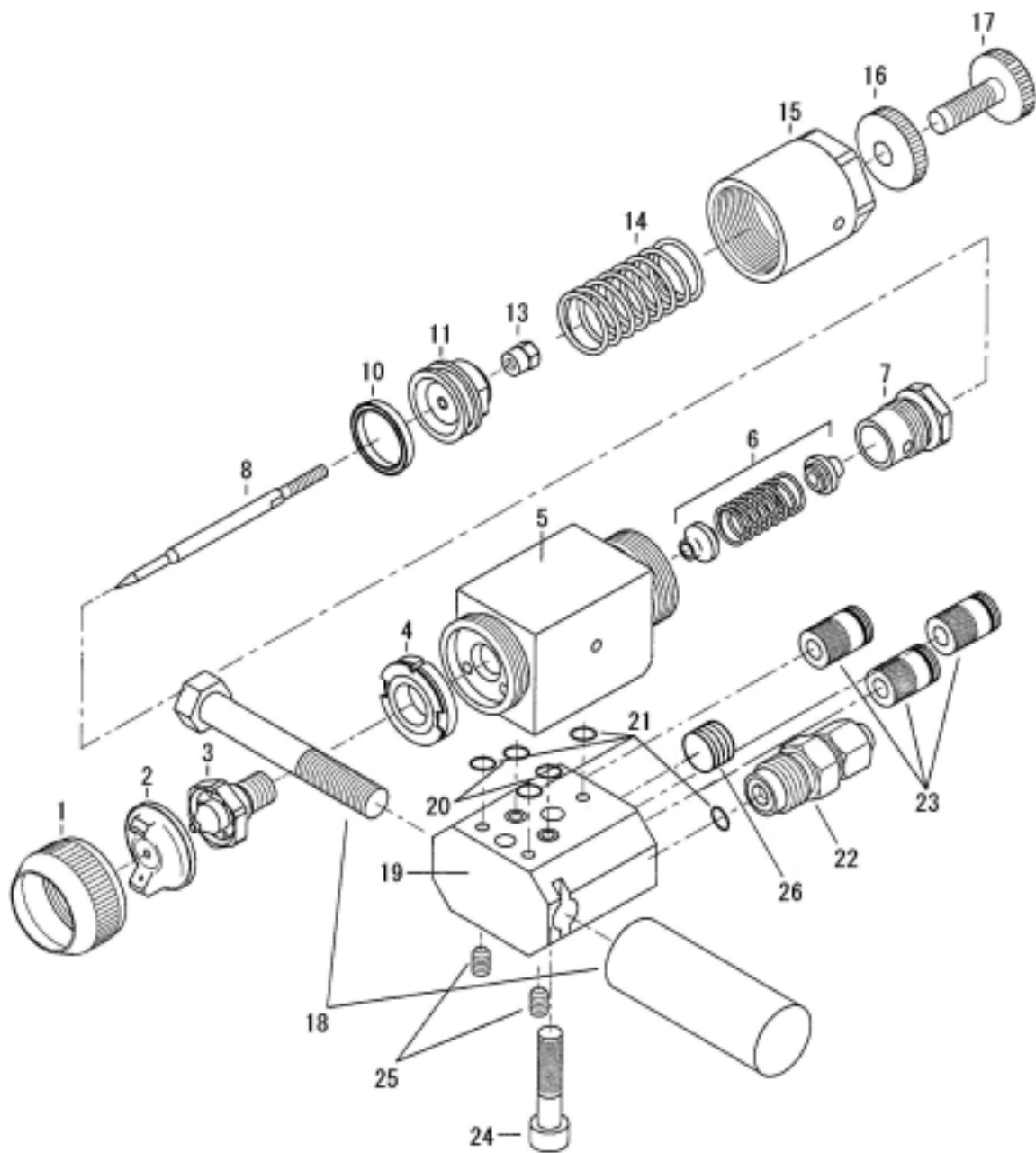



Item No.	Code No.	Part Number	Description	Q'ty	Reference
1	805577	TGA-31	Retaining Ring	1	
2		Refer to Chart 1	Air Cap	1	
3		Refer to Chart 2	Fluid Tip	1	
4	802131	AGF-5	Baffle	1	
5		_____	Gun Body	1	
6		AGX-7-K2	Needle Seal Kit (4 seals, 2 springs)	1	
7		T-AGPV-13	Housing	1	
8		Refer to Chart 2	Needle	1	
10		MY-15F	MiniY-Packing	1	
11		R-00T-103-1	Piston	1	
13		T-AGB-105	Lock Nut	1	
14		AGF-33J	Needle Spring	1	
15		T-AFPV-31	End Cap	1	
16		T-AFPV-35	Lock Nut	1	
17		T-AFPV-34	Adjusting Screw	1	
18		AGX-3-K	Mounting Stud Kit	1	
19		_____	Manifold	1	
20		SSG-8190-K5	PTFE O-Ring Kit of 5	2	
21	111065-K	7554-5-K10	O-Ring Kit of 10	4	5 for circulating
22		EF7014-1	Connector Kit for Fluid w/O-Ring	1	2 for circulating
23		EC-6-R1/8A-M-R1001	Air Connector	3	
24		_____	Bolt with Hex hole M8xL25 Set	1	
25		_____	Screw M5xL8	2	
26		_____	Plug 1/8	1	None for circulating

SERVICE CHECK



Normal Spray Pattern

The proper combination of fluid pressure, fan and atomization air pressure, and fluid tip size should result in a pattern of this shape.

PROBLEM	CAUSE	CORRECTION
Will not spray.	No pressure to gun. Piston stops moving.	Check air and material lines. Check CYL air pressure.
Improper spray pattern. 	A. Gun not adjusted properly. A, B Material build up on the air cap (2) or fluid tip (3). Note To determine where the material build up is, rotate the air cap 180 ° and test spray. If the pattern stays in the same position, the condition is caused by material build up on the fluid tip. If the pattern changes with air cap movement, the build up is in the air cap. C, D. Wrong material or material too thick. Insufficient material or atomizing air pressure too high.	A. Re-adjust. See "Operation Section". A, B Clean the air cap or fluid tip. See "Preventive Maintenance". C, D Adjust material pressure or thin material. Increase material or reduce atomizing air pressure.
Jerky or fluttering spray. 	1. Insufficient material in the tank or an obstruction in the line. 2. Gun material passage plugged. 3. Worn Needle Seal Kit (6). 4. Loose or damaged Fluid Tip (3).	1. Fill tank or clear obstruction. 2. Clean. 3. Replace or tighten. 4. Tighten or replace.
Air leaking from End Cap (15).	1. Damaged or worn MiniY-Packing (10). 2. Damaged cylinder of Gun Body (5).	1. Replace. 2. Replace.
Dripping from Fluid Tip.	1. Worn or damaged Fluid Tip (3) or Needle (12). 2. Needle Spring (18) damaged or deformed. 3.	1. Replace. 2. Replace.
Air or fluid leaking from Gun Body (5).	Damaged or worn Needle Seal Kit (6)	Replace.

ACCESSORIES

Code No.	Part Number	Description
805153	SSL-10	Gun Lube
806472	42884-214-K5	Cleaning Brush Kit of 5
800163	GC-100-K48	Gun Cover Kit of 48
HD-505-W		Quick Cleaner
800279	QMGZ-5200	Solvent Saver (10L)

DEVILBISS DIVISION

RANSBURG INDUSTRIAL FINISHING KK

15-5, Fuku-ura 1Chome, Kanazawa-ku, Yokohama, Japan 〒236-0004
TEL.81-45-785-6371 FAX.81-45-785-6517

For more information, please contact: